

THIS DRAWING IS PROPRIETARY TO DSS  
 NO PART OF THIS DRAWING MAY BE REPRODUCED  
 WITHOUT THE PERMISSION OF DSS  
 허가없이 복사할 수 없음

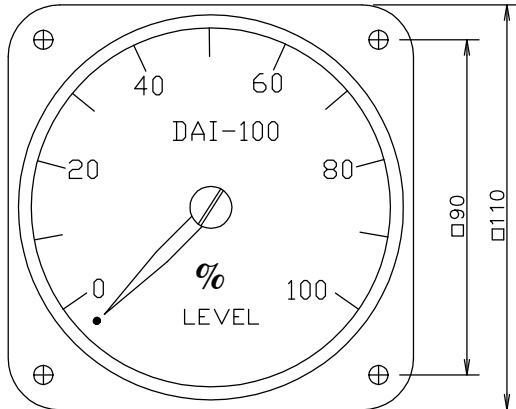
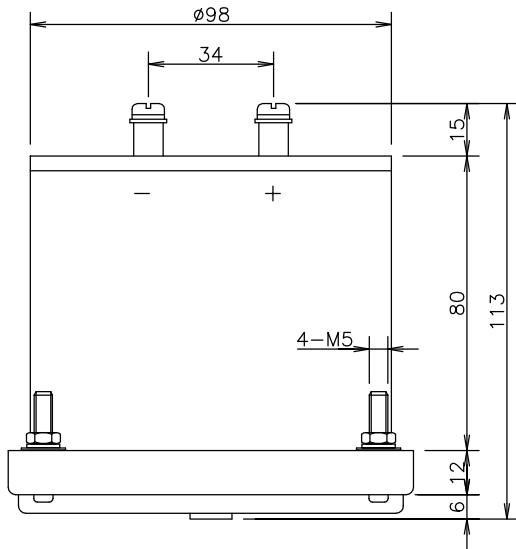

SPECIFICATION	
MODEL NAME	DAI-100
INPUT SIGNAL	4~20mA DC
INTERNAL RESISTANCE	1.5Ω
APPLICATIONS	FOR PANEL LOCAL INDICATION
CLASS	1.5 F.S
MOUNTING METHOD	PANEL MOUNT
SCALE RANGE	0~100%
AMBIENT TEMPERATURE	-20 ~ +60°C
WEIGHT	APPROX. 450g
DIMENSION (mm)	110x110 SQUARE
REMARKS:	

배 부 처	APPD BY					TOLERANCES--UNLESS OTHERWISE SPECIFIED					
	REVISION					WORK SIZE	TURN PUNCH'G DIST.OF HOLE STR.	MLDG. DIE CSTG. PRCN.CSTG DRAW.	SH.MET WELD GAS CTG.	CSTG. FORG.	
	DATE										OVER
	NO										
<b>DONG SUNG SENSORS CO.</b> TEL 02)2101-0688~9 FAX 02)2101-0687		UNIT 단위	MM. #NCH#	APPAR.							
(표준) DRWN BY 제도 DSND BY 설계 CHKD BY 검토 APPD BY 승인		SCALE 척도	N/S	TITLE 제목							
임시		J.H.HAN		K.B.HAN		3RD ANGLE 3 각 법		DAI-100			
보류						REF. NO 참고도면		DWG. NO 도면번호		1/1	
DATE		2017.06.27		2017.06.28							