

ON S/W/D

THIS DRAWING IS PROPRIETARY TO DSS
NO PART OF THIS DRAWING MAY BE REPRODUCED
WITHOUT THE PERMISSION OF DSS
©기밀정보 회사명 주. 0000

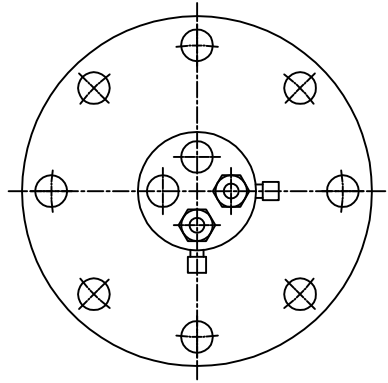
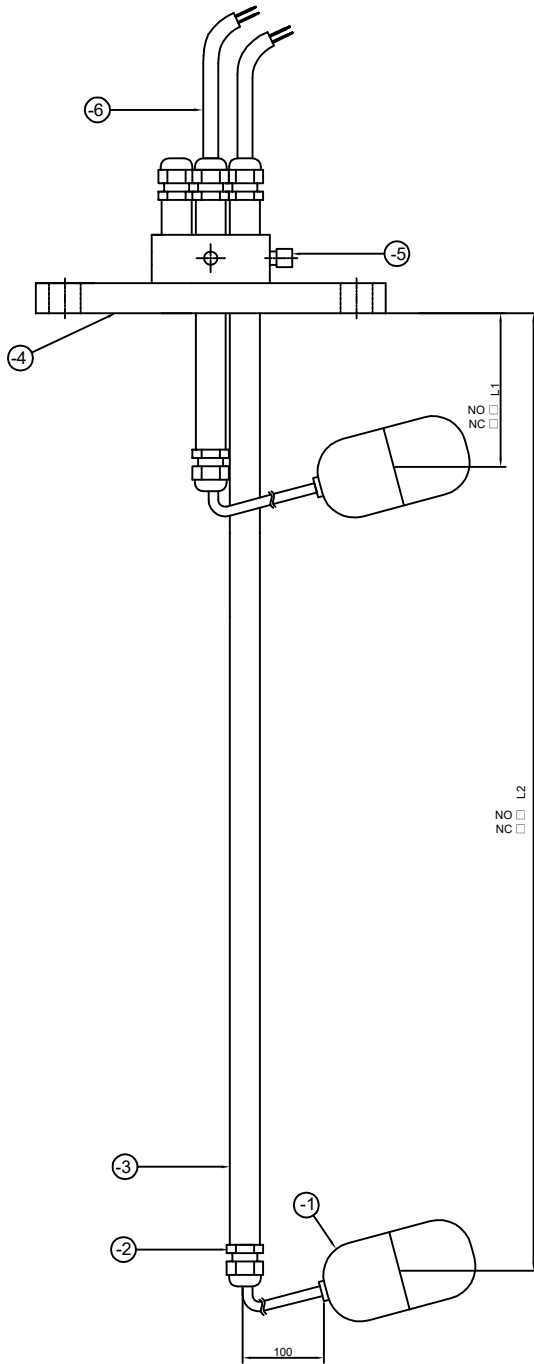

배부처

NO	DATE	REVISION	APPD BY	K.B.HAN	TOLERANCES-UNLESS OTHERWISE SPECIFIED				
					WORK SIZE	TURN PUNCH DIST OF HOLE STR	MILDG. DIE CSTG. PRON. CSTG. DRAW	SHMET WELD GAS CTG.	CSTG. FORG.
1	4	±0.1	±0.2	±0.3	±0.5				
4	16	±0.2	±0.3	±0.5	±0.7				
16	63	±0.3	±0.4	±0.7	±0.9				
63	250	±0.4	±0.5	±1.2	±1.3				
250	500	±0.6	±0.8	±1.5	±1.8				
500	1000	±0.8	±1.0	±2.0	±2.5				
1000	2000	±1.2	±1.5	±2.5	±3.3				
	ANGLE	±.25°	±.5°	±1.0°	±2.0°				

DONG SUNG SENSORS CO.,LTD. TEL:(02)2101-0688-9 FAX:(02)2101-0687				UNIT 단위	MM, INCH
표준	DRWN BY 제도	DSND BY 설계	CHKD BY 검토	APPD BY 승인	SCALE 척도
임시	J.H.HAN	K.B.HAN			N/S
보류	2023.03.25.	2023.03.25.			3RD ANGLE 3 각 법
DATE	2023.03.25.	2023.03.25.			REF. NO 참고도면

APPAR.	-
TITLE 제목	DQ-22FN
DWG. NO 도면번호	-

	L1	L2	L3	L4
-6	CABLE	2	P.V.C	
-5	UP/DOWN BOLT	2	P.V.C	
-4	FLANGE	1	P.V.C	
-3	GUIDE PIPE	2	P.V.C	
-2	CABLE GRAND	4	A.B.S	
-1	DQ-2	2	A.B.S	
1	DQ-22FN	1SET	-	
ITEM NO	PART NAME	QTY	MATERIAL	
SPECIFICATION				
MODEL NAME		DQ-22FN		
PRESSURE		A.T.M		
TEMPERATURE		MAX.50°C		
APPLICATIONS		WATER, SLUDGY LIQUID, FACTORY DRAINAGE		
SWITCHING CURRENT		AC220V, 3A		
MOUNTING METHOD		TOP		
MOUNTING SIZE		ORDER MADE		
REMARKS :				
ORDER MADE(L1, L2, L3, L4)				

(UNIT:mm)