

ON GWD
-
-

THIS DRAWING IS PROPRIETARY TO DSS
NO PART OF THIS DRAWING MAY BE REPRODUCED
WITHOUT THE PERMISSION OF DSS
해가없이 복사할 수 없음

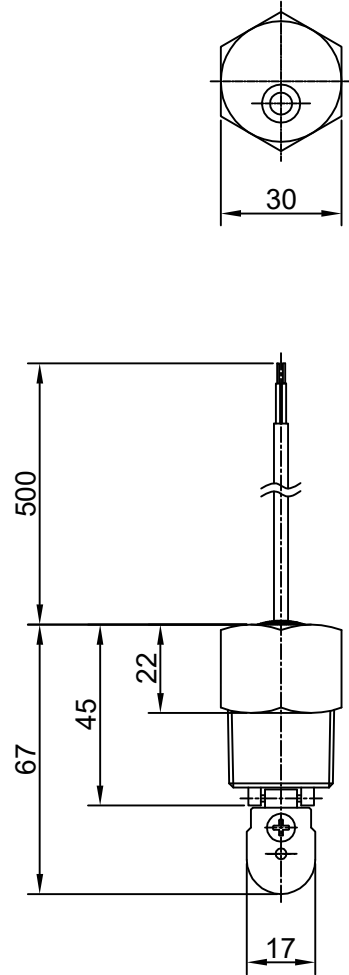
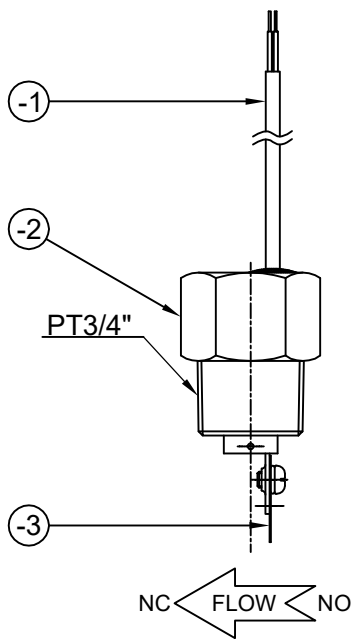

배부처	

-3	PADDLE	1	SUS304
-2	BODY	1	SUS304
-1	LEAD WIRES	1	P.V.C
1	DFS-2-3/4SR	1SET	-
ITEM NO	PART NAME	Q'TY	MATERIAL
SPECIFICATION			
MODEL NAME		DFS-2-3/4SR	
PRESSURE		MAX.10Kgf/cm ²	
TEMPERATURE		MAX.100°C	
SWITCHING CURRENT		AC220V, 1A, 50VA	
MOUNTING METHOD		HORIZONTAL, VERTICAL	
MOUNTING SIZE		PT3/4"	
FLOW RATE		25~15L/Min	
APPLICATIONS		WATER, OIL	
REMARKS :			

NO	DATE	2014.01.27	APPD BY K.B.HAN	TOLERANCES-UNLESS OTHERWISE SPECIFIED	DONG SUNG SENSORS CO.,LTD. TEL:(02)2101-0688~9 FAX:(02)2101-0687	UNIT	MM, INCH	APPAR.	-
	REVISION	INITIAL RELEASE				SCALE	N/S		
1	4	±0.1	±0.2	±0.3	±0.5	3RD ANGLE	3각법		
4	16	±0.2	±0.3	±0.5	±0.7	DRWN BY	J.S.LIM	DSND BY	K.B.HAN
16	63	±0.3	±0.4	±0.7	±0.9	CHKD BY		APPD BY	
63	250	±0.4	±0.6	±1.2	±1.3	DATE	2013.12.16.	2014.01.14.	
250	500	±0.6	±0.8	±1.5	±1.8	REF. NO	참고도면	DWG. NO	도면번호
500	1000	±0.8	±1.0	±2.0	±2.5				1/1
1000	2000	±1.2	±1.5	±2.5	±3.3				
ANGLE	±25°	±5°	±1.0	±2.0					