

THIS DRAWING IS PROPRIETARY TO DSS
NO PART OF THIS DRAWING MAY BE REPRODUCED
WITHOUT THE PERMISSION OF DSS
형기없이 복사할 수 없음

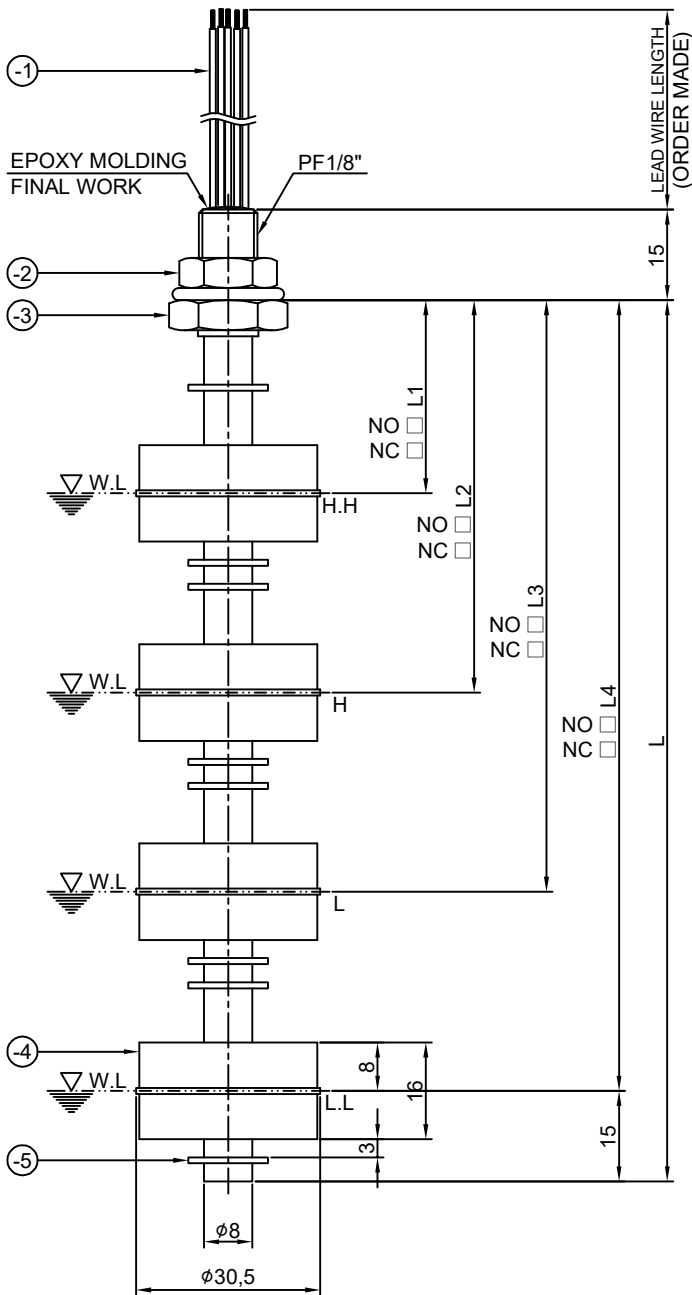

(UNIT:mm)

	L	L1	L2	L3	L4
-5					
-4					
-3					
-2					
-1					
1					
ITEM NO	PART NAME	Q'TY	MATERIAL		

SPECIFICATION

MODEL NAME	DFR-2C-4F
PRESSURE	MAX.2Kgf/cm ²
TEMPERATURE	MAX.90°C
APPLICATIONS	WATER, OIL
SWITCHING CURRENT	AC220V,0.2A,50VA
MOUNTING METHOD	TOP & BOTTOM
MOUNTING SIZE	PF1/8"

REMARKS :
ORDER MADE(L1, L2, L3,L4, L=L4+15)

배부처

NO	DATE	REVISION	BY	INITIAL RELEASE	DATE	WORK SIZE	TURNOVER DIST. OF HOLE STR.	MOLDING PRON. CSTG. DRAW.	SH. MET WELD GAB. CSTG.	CSTG. FORG.
1	4					±0.1	±0.2	±0.3	±0.5	
4	16					±0.2	±0.3	±0.5	±0.7	
16	63					±0.3	±0.4	±0.7	±0.9	
63	250					±0.4	±0.5	±1.2	±1.3	
250	500					±0.6	±0.8	±1.5	±1.8	
500	1000					±0.8	±1.0	±2.0	±2.5	
1000	2000					±1.2	±1.5	±2.5	±3.3	
ANGLE		±.25°				±.5°		±1.0°	±2.0°	

DONG SUNG SENSORS CO.,LTD.
TEL:(02)2101-0688~9 FAX:(02)2101-0687

표준
임시
분류

DRWN BY: J.H.HAN
DSND BY: K.B.HAN
CHKD BY: K.B.HAN
APPD BY: K.B.HAN

DATE: 2017.04.27. 2017.04.27.

UNIT 단위	MM, INCH
SCALE 척도	N/S
3RD ANGLE 각 방법	
REF. NO 참고도면	

APPAR.	-
TITLE 제목	DFR-2C-4F
DWG. NO 도면번호	-
	1/1