

DWG ON

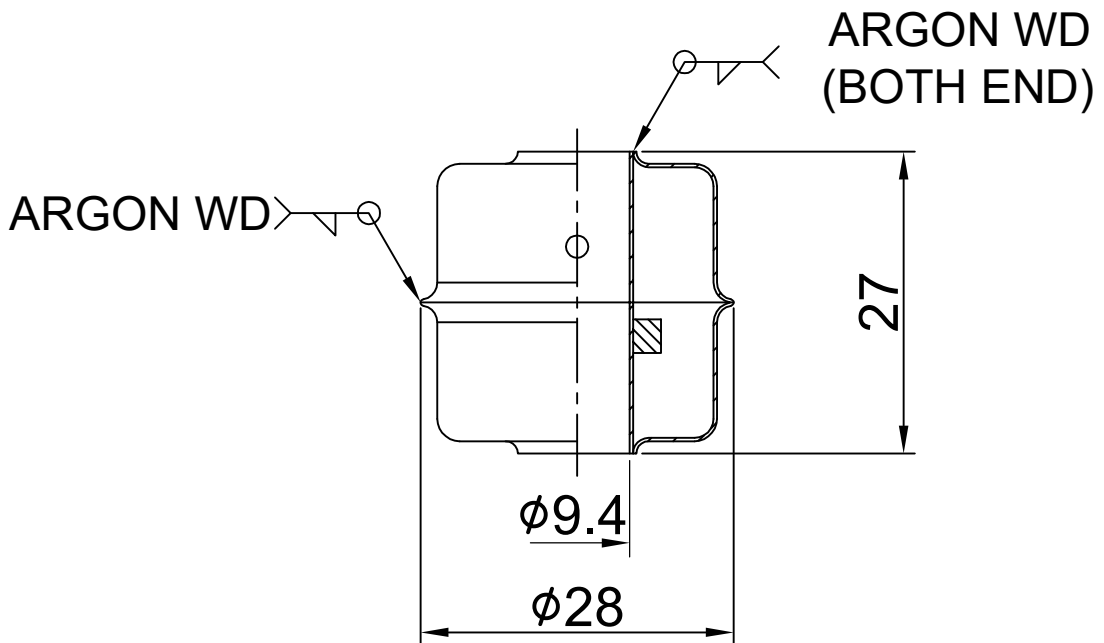
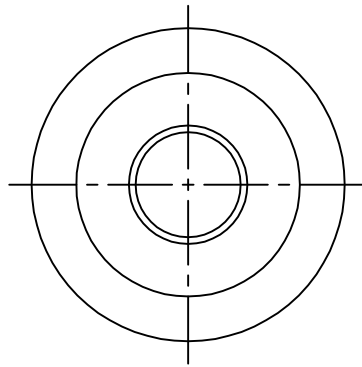

THIS DRAWING IS PROPRIETARY TO DSS.
NO PART OF THIS DRAWING MAY BE REPRODUCED
WITHOUT THE PERMISSION OF DSS.
이 기 도 면 이 독 사 물 수 없 습

배 부 처

1	DF-S51	1	SUS316L
ITEM NO	PART NAME	Q'TY	MATERIAL
SPECIFICATION			
MODEL NAME		DF-S51	
PRESSURE		MAX.20Kgf/cm ²	
TEMPERATURE		일반용 MAX.100°C	고온용 MAX.160°C
DIMENSION		$\phi 28 \times \phi 9.4 \times 27$	
WEIGHT		7.6g	
SPECIFIC GRAVITY		0.66	
REMARKS :			

NO	DATE	REVISION	APPD BY K.P.HAN	TOLERANCES-UNLESS OTHERWISE SPECIFIED					DONG SUNG SENSORS CO.,LTD. TEL:(02)2101-0688-9 FAX:(02)2101-0687	UNIT 단 위 MM, INCH	APPAR.	-			
				WORK SIZE	TURN FINISHG DIST OF HOLE STR.	MILDG. DIE CSTG. DRWG. DRAW.	SH MET WELD GAS CTG.	CSTG. FORG.					SCALE 력 도		
1	4			±0.1	±0.2	±0.3	±0.5	표준	DRWN BY 제 도	DSND BY 설 계	CHKD BY 검 토	APPD BY 승 인	TITLE 제 목	DF-S51	
4	16			±0.2	±0.3	±0.5	±0.7	임시	J.H.HAN	K.B.HAN					
16	83			±0.3	±0.4	±0.7	±0.9	도류							
63	250			±0.4	±0.5	±1.2	±1.3								
250	500			±0.6	±0.8	±1.5	±1.8								
500	1000			±0.8	±1.0	±2.0	±2.5								
1000	2000			±1.2	±1.5	±2.5	±3.3								
ANGLE				±.25°	±.5°	±1.0°	±2.0°		DATE	2017.08.21	2017.08.21.	REF. NO 참 고 도 면	DWG. NO 도 면 번 호	-	1/1