

ON DWG

THIS DRAWING IS PROPRIETARY TO DSS
NO PART OF THIS DRAWING MAY BE REPRODUCED
WITHOUT THE PERMISSION OF DSS
해당제품의 표시를 수 없음

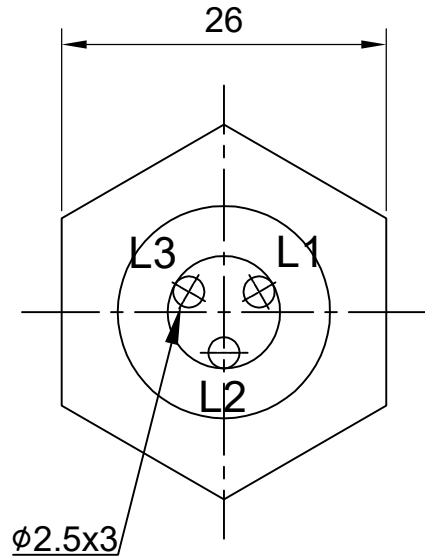
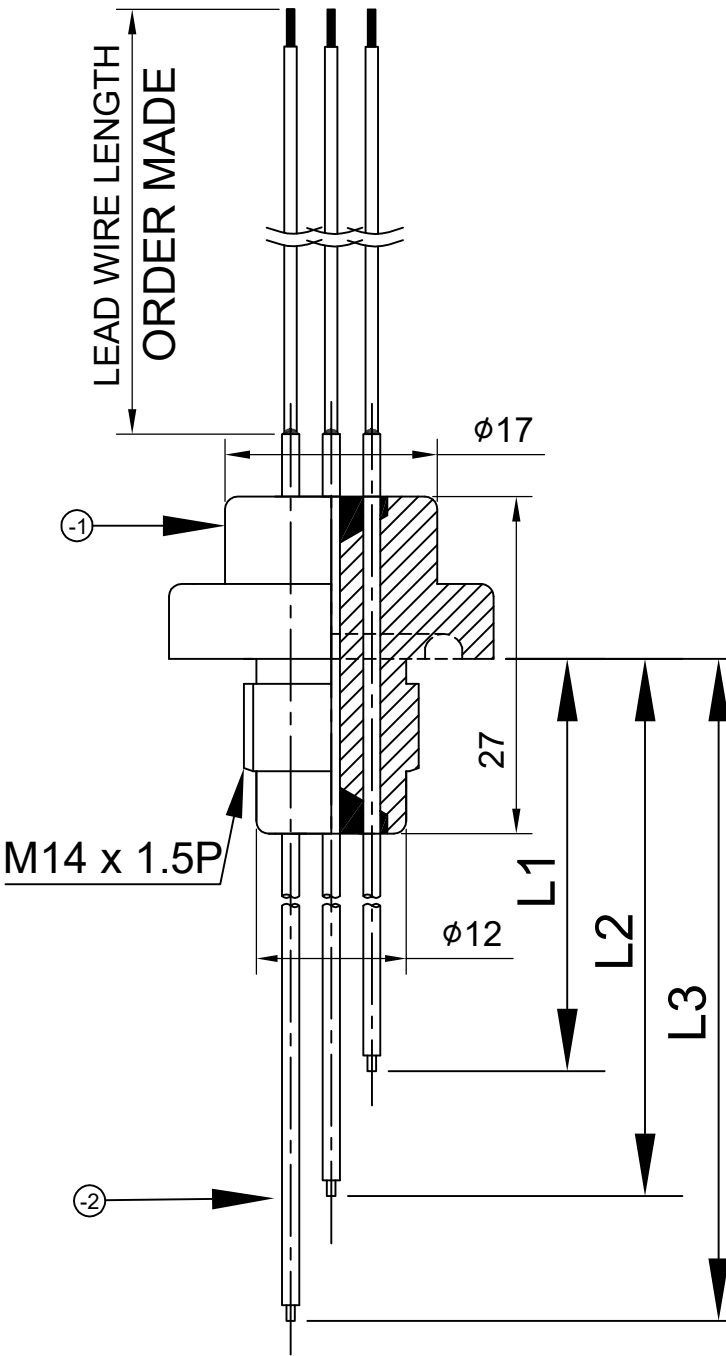

L1 : mm
L2 : mm
L3 : mm

(UNIT:mm)

L1	L2	L3		
-2	ELECTRODE	3	PTFE+SUS304	
-1	HEAD	1	MC	
1	DES-3	1SET	-	
ITEM NO	PART NAME	QTY	MATERIAL	
SPECIFICATION				
MODEL NAME		DES-3		
PRESSURE		A.T.M		
TEMPERATURE		-10~+60°C		
APPLICATIONS		WATER		
WIRE CONNECTION		3-WIRE		
MOUNTING METHOD		TOP		
MOUNTING SIZE		M14		
LOOP IMPEDANCE		500Ω(15V DC)		
MEASURING RANGE		ORDER MADE		
REMARKS :				

배부처

NO	DATE	REVISION	APPD BY	BY	TOLERANCES-UNLESS OTHERWISE SPECIFIED					
					WORK SIZE	FURN FINCHG DIST OF HOLE STR.	MLOG. DIE CSTG. PRCN. CSTG. DRAW.	SH MET WELD GAS CTG.	CSTG. FORG.	
1	4	±0.1	±0.2	±0.3	±0.5					
4	16	±0.2	±0.3	±0.5	±0.7					
16	63	±0.3	±0.4	±0.7	±0.9					
63	250	±0.4	±0.5	±1.2	±1.3					
250	500	±0.6	±0.8	±1.5	±1.8					
500	1000	±0.8	±1.0	±2.0	±2.5					
1000	2000	±1.2	±1.5	±2.5	±3.3					
	ANGLE	±.25°	±.5°	±1.0°	±2.0°					

☀ DONG SUNG SENSORS CO.,LTD.
TEL:(02)2101-0688~9 FAX:(02)2101-0687

DRWN BY	DSND BY	CHKD BY	APPD BY
제도	설계	검토	승인
J.H.HAN	K.B.HAN		
DATE	2017.06.27.	2017.06.28.	

UNIT	MM, INCH	APPAR.	-
SCALE	N/S	TITLE	DES - 3
	3RD ANGLE	DWG. NO	-
	3 각 법	도면번호	1/1
	REF. NO		
	참고도면		