

DWG NO  
-

THIS DRAWING IS PROPRIETARY TO DSS  
NO PART OF THIS DRAWING MAY BE REPRODUCED  
WITHOUT THE PERMISSION OF DSS  
중기(주)의 재산권은 본 도면에

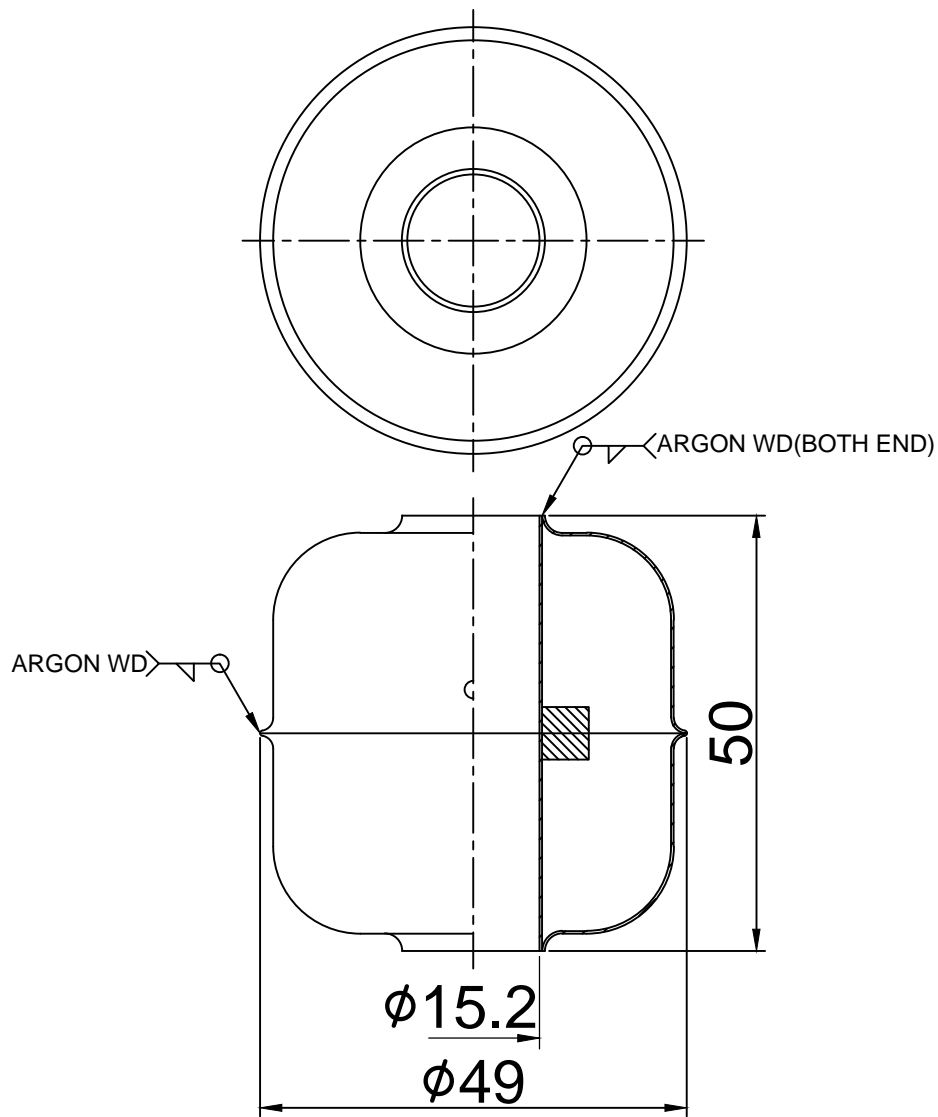

배부처									

1	DF-S14	1	SUS304
ITEM NO	PART NAME	Q'TY	MATERIAL
SPECIFICATION			
MODEL NAME		DF-S14	
PRESSURE		MAX.10Kgf/cm <sup>2</sup>	
TEMPERATURE		MAX.120°C	
DIMENSION		φ49xφ15.2x50	
WEIGHT		36g	
SPECIFIC GRAVITY		0.57	
REMARKS :			

APPD BY K.B. HAN	TOLERANCES-UNLESS OTHERWISE SPECIFIED				DONG SUNG SENSORS CO.,LTD. TEL:(02)2025-8988-9 FAX:(02)2025-8987	UNIT 단위 MM, INCH	APPAR.	-
	REVISION	NO	DATE	2014.01.27				
INITIAL RELEASE	SIZE	WORK TURN NO. MESH	FURN PCHG DIST OF HOLE STR	MOLD DIE CSTG. PRCN. CSTG DRAW.	SHMET WELD GAS CTG.	CSTG. FORG.	TITLE 제목	DF-S14
1	4	±0.1	±0.2	±0.3	±0.5	±0.7	3RD ANGLE 3 각 법	
4	16	±0.2	±0.3	±0.5	±0.7	±0.9	REF. NO 참고도면	
16	63	±0.3	±0.4	±0.7	±1.2	±1.3	DWG. NO 도면번호	-
63	250	±0.4	±0.5	±1.0	±1.5	±1.8		1/1
250	500	±0.5	±0.6	±1.5	±2.0	±2.5		
500	1000	±0.6	±1.0	±2.0	±3.0	±3.3		
1000	2000	±0.7	±1.5	±2.5	±3.3	±3.3		
2000		±0.8	±1.5	±2.5	±3.3	±3.3		
ANGLE	±.25°	±.5°	±1.0°	±1.0°	±2.0°	±2.0°		
DATE	2017.08.21.	DATE	2017.08.21.	DATE	2017.08.21.	DATE	2017.08.21.	
DRWN BY 제 도	J.H.HAN	DSND BY 설 계	K.B.HAN	CHKD BY 검 도		APPD BY 승 인		