

ON G/W/D
 -

THIS DRAWING IS PROPRIETARY TO DSS.
 NO PART OF THIS DRAWING MAY BE REPRODUCED
 WITHOUT THE PERMISSION OF DSS.
 이 기밀은 DSS의 재산이며 허가 없이 복제할 수 없습니다.

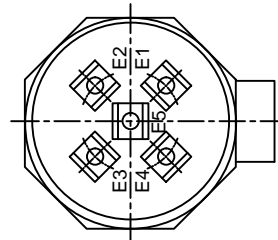
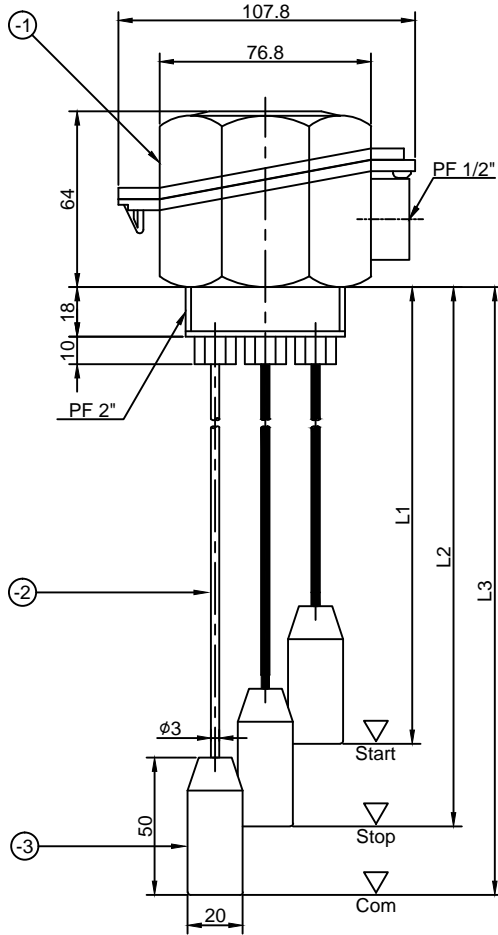

E2 : Pump Start
 E3 : Pump Stop
 E5 : Common

(UNIT:mm)

ITEM NO.	PART NAME	QTY	MATERIAL
L1			
L2			
L3			
-3	WEIGHT	3	SUS304
-2	WIRE ELECTRODE	3	SUS304
-1	HEAD	1	ABS
1	DES-3W	1SET	-
SPECIFICATION			
MODEL NAME		DES-3W	
PRESSURE		A.T.M	
TEMPERATURE		-10 ~ 60°C	
APPLICATIONS		WATER	
WIRE CONNECTION		3-WIRE	
MOUNTING METHOD		TOP	
MOUNTING SIZE		PF 2"	
LOOP IMPEDANCE		500Ω(15V DC)	
MEASURING RANGE		ORDER MADE	
REMARKS :			

배부처

NO	DATE	REVISION	INITIAL RELEASE	APPD BY	BY	TOLERANCES-UNLESS OTHERWISE SPECIFIED	DONG SUNG SENSORS CO.,LTD.	UNIT	SCALE	3RD ANGLE	REF. NO	DWG. NO
1	2014.01.27	1	K.B.HAN	K.B.HAN	DRWN BY	TEL:(02)2025-8988-9 FAX:(02)2025-8987	MM, INCH	3	N/S	각	참고도면	-
2		2			DSND BY							
3		3			CHKD BY							
4		4			APPD BY							
5		5										
6		6										
7		7										
8		8										
9		9										
10		10										
11		11										
12		12										
13		13										
14		14										
15		15										
16		16										
17		17										
18		18										
19		19										
20		20										
21		21										
22		22										
23		23										
24		24										
25		25										
26		26										
27		27										
28		28										
29		29										
30		30										
31		31										
32		32										
33		33										
34		34										
35		35										
36		36										
37		37										
38		38										
39		39										
40		40										
41		41										
42		42										
43		43										
44		44										
45		45										
46		46										
47		47										
48		48										
49		49										
50		50										
51		51										
52		52										
53		53										
54		54										
55		55										
56		56										
57		57										
58		58										
59		59										
60		60										
61		61										
62		62										
63		63										
64		64										
65		65										
66		66										
67		67										
68		68										
69		69										
70		70										
71		71										
72		72										
73		73										
74		74										
75		75										
76		76										
77		77										
78		78										
79		79										
80		80										
81		81										
82		82										
83		83										
84		84										
85		85										
86		86										
87		87										
88		88										
89		89										
90		90										
91		91										
92		92										
93		93										
94		94										
95		95										
96		96										
97		97										
98		98										
99		99										
100		100										