

DWG NO.   
 -

THIS DRAWING IS PROPRIETARY TO DSS  
 NOT TO BE REPRODUCED  
 WITHOUT THE PERMISSION OF DSS  
 허가없이 복사할 수 없음

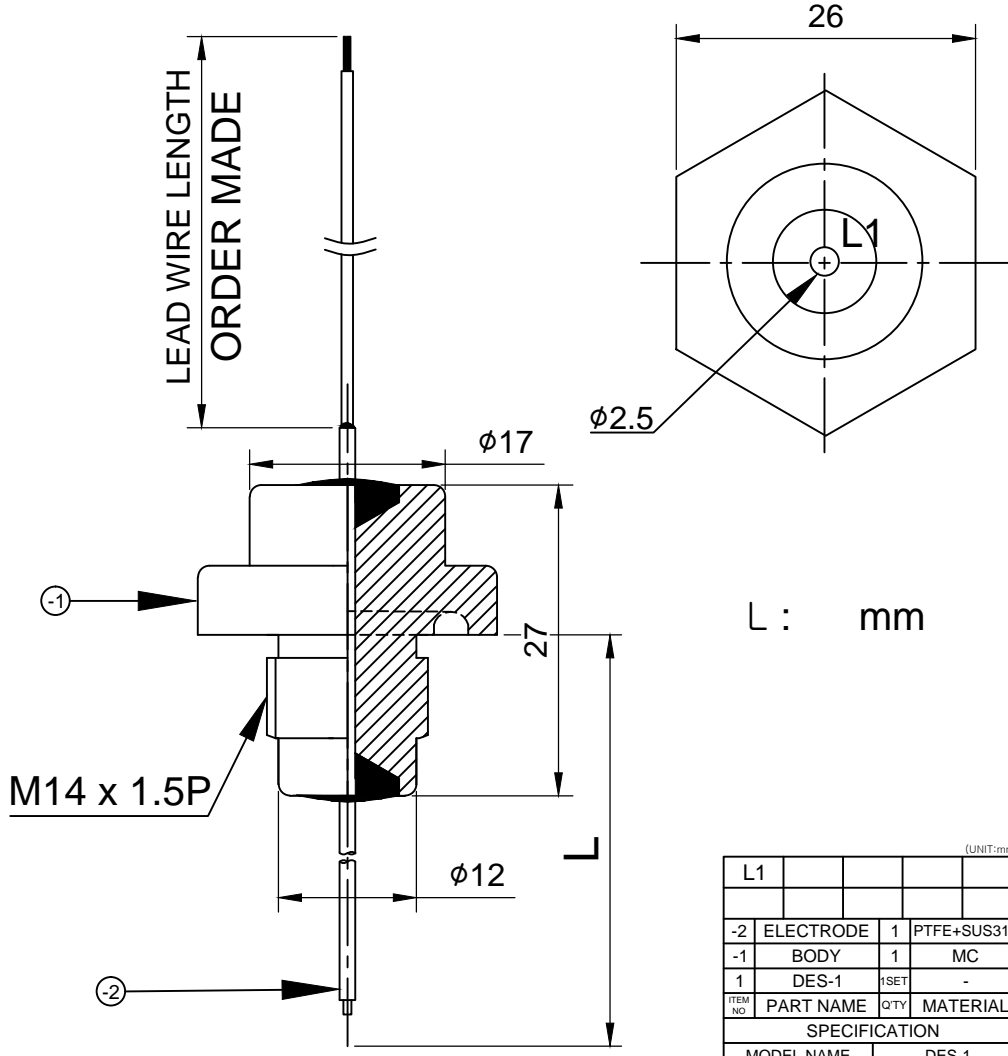

L : mm

배부처					

NO	DATE	REVISION	TOLERANCES-UNLESS OTHERWISE SPECIFIED				
			WORK SIZE	TURN PUNCH DIST OF HOLE STR.	M.D.G DIE CSTG. FROM CSTG. DRAW.	SMIET WELD GAS CTG.	CSTG. FORGL.
		INITIAL RELEASE	±0.1	±0.2	±0.3	±0.5	
		2014.01.27	±0.2	±0.3	±0.5	±0.7	
			±0.3	±0.4	±0.7	±0.9	
			±0.4	±0.5	±1.2	±1.3	
			±0.6	±1.0	±1.5	±1.8	
			±0.8	±1.0	±2.0	±2.5	
			±1.2	±1.5	±2.5	±3.3	
			±2.5	±5	±10	±20	

**DONG SUNG SENSORS CO.,LTD.**  
 TEL:(02)2025-8988-9 FAX:(02)2025-8987

DRWN BY: J.H.HAN  
 DSND BY: K.B.HAN  
 CHKD BY: K.B.HAN  
 APPD BY: K.B.HAN

DATE: 2017.06.27. 2017.06.28.

UNIT: MM, INCH  
 SCALE: N/S  
 3RD ANGLE  
 REF. NO: 참고도면

SPECIFICATION			
MODEL NAME	DES-1		
PRESSURE	A.T.M		
TEMPERATURE	-10~+60°C		
APPLICATIONS	WATER		
WIRE CONNECTION	1-WIRE		
MOUNTING METHOD	TOP		
MOUNTING SIZE	M14		
MEASURING RANGE	ORDER MADE		
REMARKS :			

ITEM NO.	PART NAME	QTY	MATERIAL
-2	ELECTRODE	1	PTFE+SUS316
-1	BODY	1	MC
1	DES-1	1SET	-

TITLE: DES - 1  
 DWG. NO: -  
 도면번호: 1/1