

THIS DRAWING IS PROPRIETARY TO DSS
NO PART OF THIS DRAWING MAY BE
REPRODUCED WITHOUT THE PERMISSION OF DSS
DONG SUNG SENSORS CO., LTD.

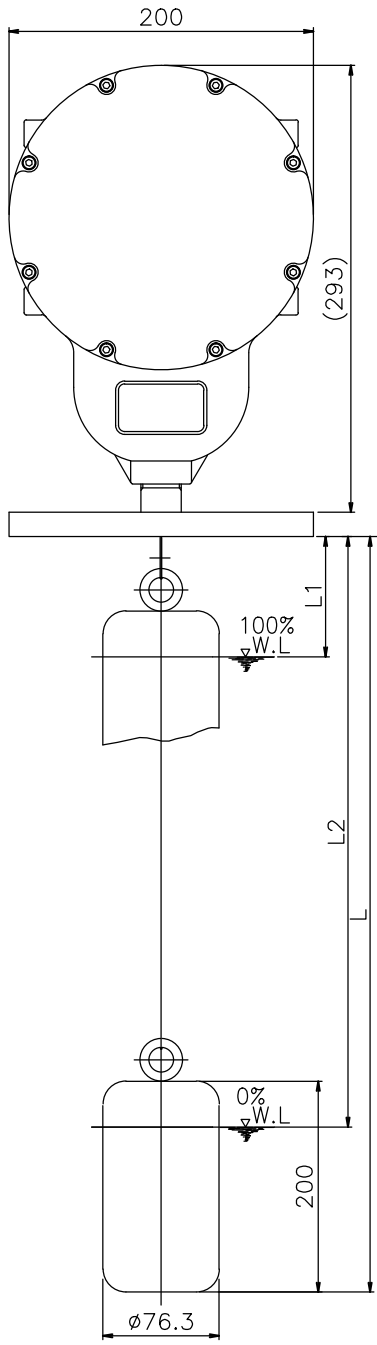

배 부 처

SPECIFICATION	
MODEL NAME	DGL-200S
MEASURING MATERIAL	LIQUID
OUTPUT	4~20mA
ACCURACY	±20mm
MEASURING RANGE	MAX. 10m
SPECIFIC GRAVITY	0.8
OPERATING PRESSURE	MAX 0.2Kg.f/cm2
AMBIENT TEMPERATURE	MAX -20~+80°C
BLANKING AREA	100mm
DIMENSION	200(W)x293(H)x202(D)
FLOAT DIMENSION	φ76.3x200(H)
ENCLOSURE	WEATHER PROOF
MATERIAL	BODY : SMC FLANGE : SUS304 WIRE : SUS316 FLOAT : SUS304
INPUT POWER	DC15~32V, 2WIRE LOOP
LOOP IMPEDANCE	450 Ohme (DC24V)
CALIBRATION	ZERO & SPAN
REMARKS:	MEASURING LENGTH=ORDER SPEC.(L1,L2)

TOLERANCES-UNLESS OTHERWISE SPECIFIED DONG SUNG SENSORS CO.,LTD. TEL<02>2025-8988-9 FAX<02>2025-8987		UNIT	MM, INCH	APPAR.	-
NO	DATE	REVISION	INITIAL	K.B.HAN	DATE
1	2014.01.27	1	4	0.1	± 0.2
4	16	± 0.2	± 0.3	± 0.5	± 0.7
16	63	± 0.3	± 0.4	± 0.7	± 0.9
63	250	± 0.4	± 0.6	± 1.2	± 1.3
250	500	± 0.6	± 0.8	± 1.5	± 1.8
500	1000	± 0.8	± 1.0	± 2.0	± 2.5
1000	2000	± 1.0	± 1.5	± 2.5	± 3.3
ANGLE	± .25°	± .5°	± 1.0°	± 2.0°	
DATE	2019.02.26.	2019.02.26.	DRWN BY	J.H.HAN	CHKD BY
			DSND BY	K.B.HAN	APPD BY
			인시		
			분류		

SCALE	N/S	TITLE	DGL-200S
3RD ANGLE	각	제 목	
REF. NO		DWG. NO	
참고도면		도면번호	
			1/1